

---

# BTP-S80

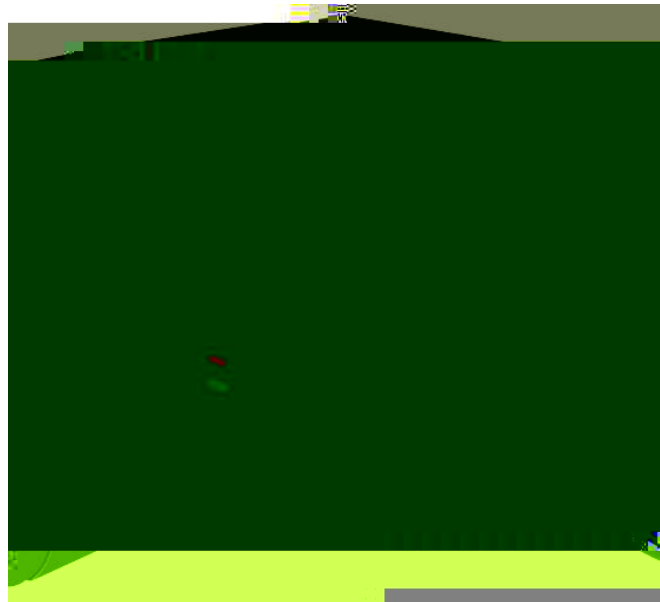



**1**



**2**

1)

2)

3)

4)

5)

6)

7)

8)

9)

10)

11)

12)

13)

14)

15)

	.....	<b>1</b>
1.1	.....	1
1.2	.....	1
	.....	<b>2</b>
2.1	.....	2
2.2	.....	4
2.3	.....	4
2.3.1	.....	4
2.3.2	.....0.0ET. EMC.....	4
	.....0.0ET. EM.....0.0ET. EMC.....0.0ET. EMC.....	<b>6</b>
3.1	.....	6
3.2	.....	7
<b>1</b>	.....	<b>9</b>
4.1	.....	9
4.2	.....	9
4.3	.....	10
4.3.1	.....	10
4.3.2	0.....	10
4.3.3	USB .....	10
4.3.4	.....	10
4.4	.....	11
4.4.1	.....	11
4.4.2	/ .....	11
4.5	468 .....	

---

6.6	.....	20
6.7	.....	20
<b>4</b>	.....	<b>22</b>
7.1	.....	22
7.2	.....	22
7.3	.....	22
<b>5</b>	.....	<b>23</b>
<b>6</b>	<b>M</b> .....	<b>24</b>

**1.1**

BTP-S80

USB

Windows 2000/XP/Server 2003/Vista/Server2000/Win7/

Win8/Win8.1/Win10/Server 2012 POSReady2009/POSReady7 Linux Mac

UPOS

**1.2**



## 2.1

		203 × 203DPI 203 × 180DPI
		57.5/80/82.5mm
		80mm
		250mm/s
	Flash LOGO	1M
		64K      4K      45
	USB	USB2.0
		RS-232C
		IEEE1284
		10/100BASE-T
		1 2
		RAM: 2MB, Flash: 4MB
	1D	UPC-A, UPC-E, CODE 39, CODE 93, CODE 128, EAN8, EAN13, ITF, CODABAR
	2D	PDF417, QR, Maxicode
		Font A: 12 × 24 Font B: 9 × 17 Kanji font A: 24 × 24
		95 Alphanumeric
		14
		128 x 68
		GB2312/18030
		95 &
		1-6
		(0 90 180 270 )
		ESC/POS
		83mm

		0.06mm~0.10mm
		100-240V 50-60Hz
		24V ± 5% 2A
		24V
		12.5%
		200
	MCBF	70,000,000
	MTBF	360,000
		5°C 45°C 20% 90%RH 40°C
		-40°C 60°C 10% 90%RH 40°C
		127mm L *127mm W *134mm H

2.1-1

**2.2**

	500ms	
	3s	20 /
	0.06mm~0.10mm	
	24VDC	
	1.2A	24VDC
	200	

2.2-1

**2.3**

**2.3.1**

57.5/80/82.5mm

0.06mm-0.10mm

Max. 83mm

Min. 12.8mm



15%

85



70 °C

13mm



**3.1**

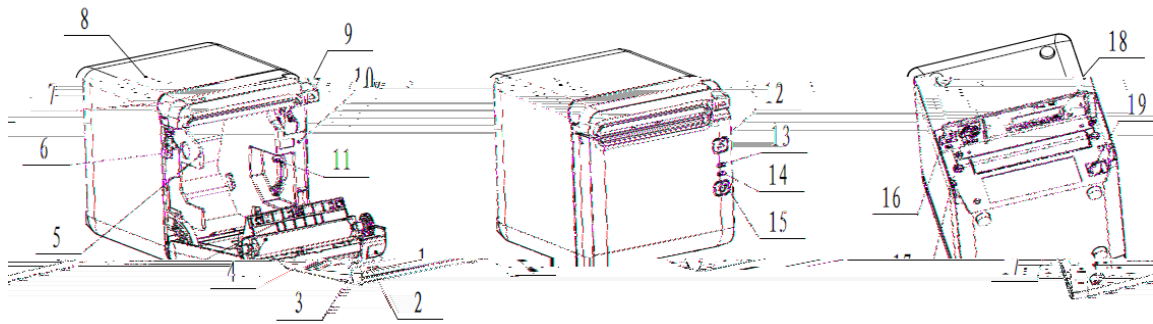

**3.1-1**

- |     |     |     |        |
|-----|-----|-----|--------|
| 1—  | 2—  | 3—  | 4—     |
| 5—  | 6—  | 7—  | 8—     |
| 9—  | 10— | 11— | 12—    |
| 13— | 14— | 15— | 16—USB |
| 17— | 18— | 19— |        |

a 12

( ) FEED

b 13

c 14

d 15

e 6

f 4

g 7

h 5

58/80mm,

82.5mm

**3.2**

1)

3.2-1

2)



3.2-2





**4.3**



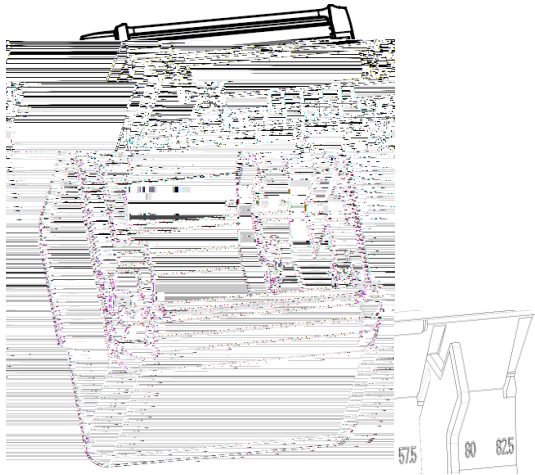

4.4-3 57.5

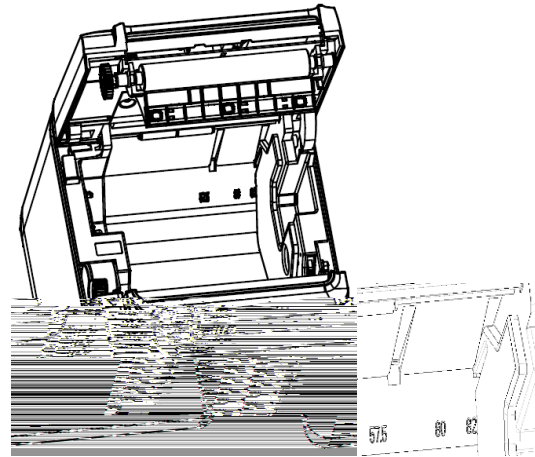

4.4-4 80

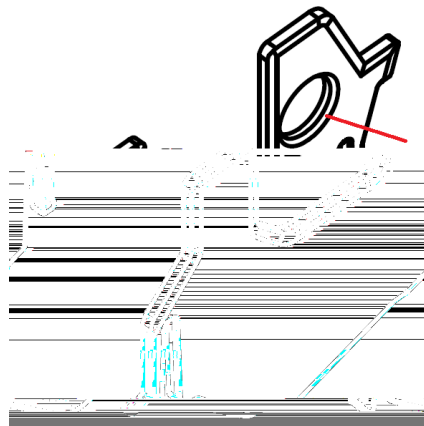

4.4-5

## 4.5

### 4.5.1

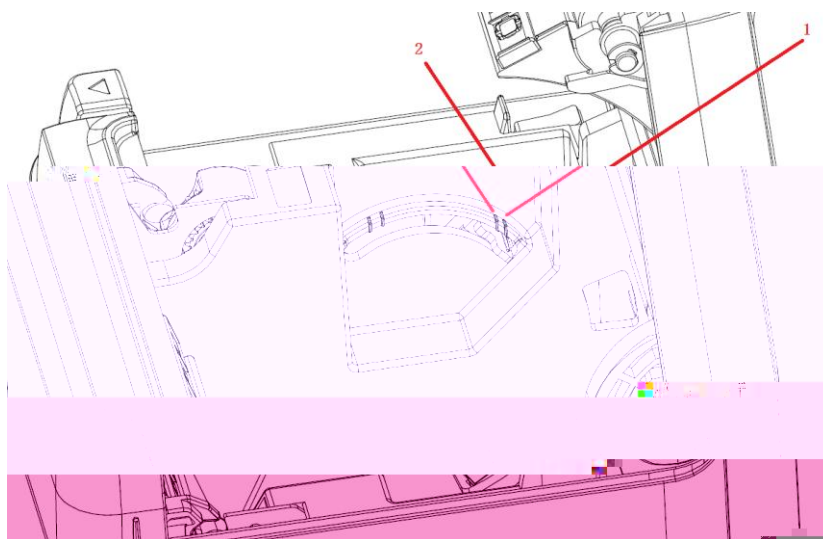

4.5-1

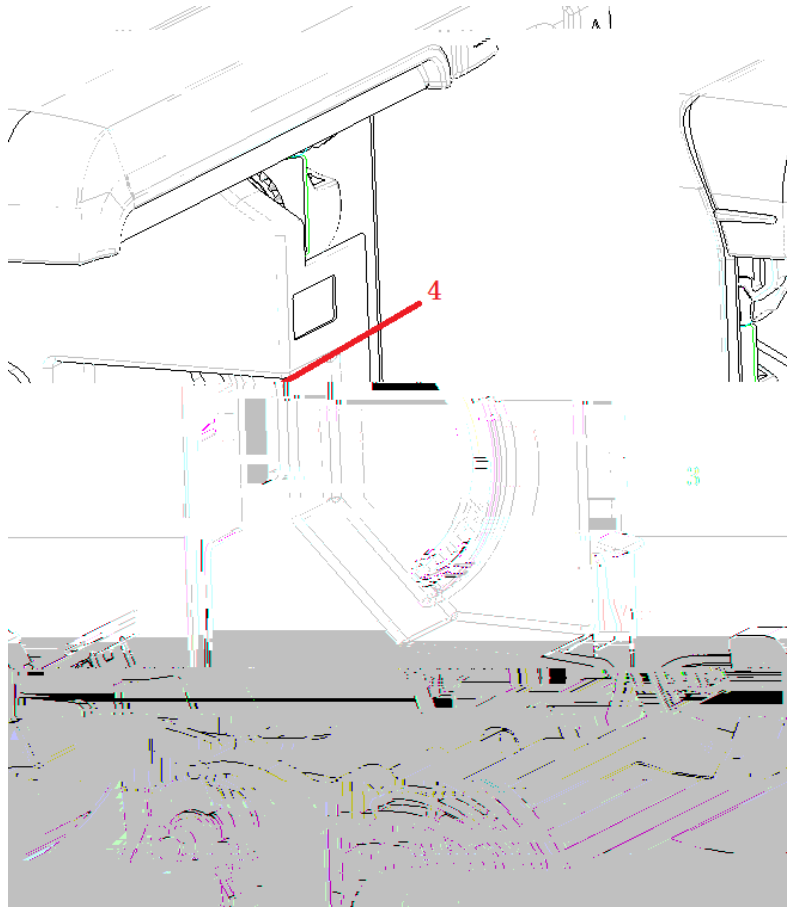

4.5-2

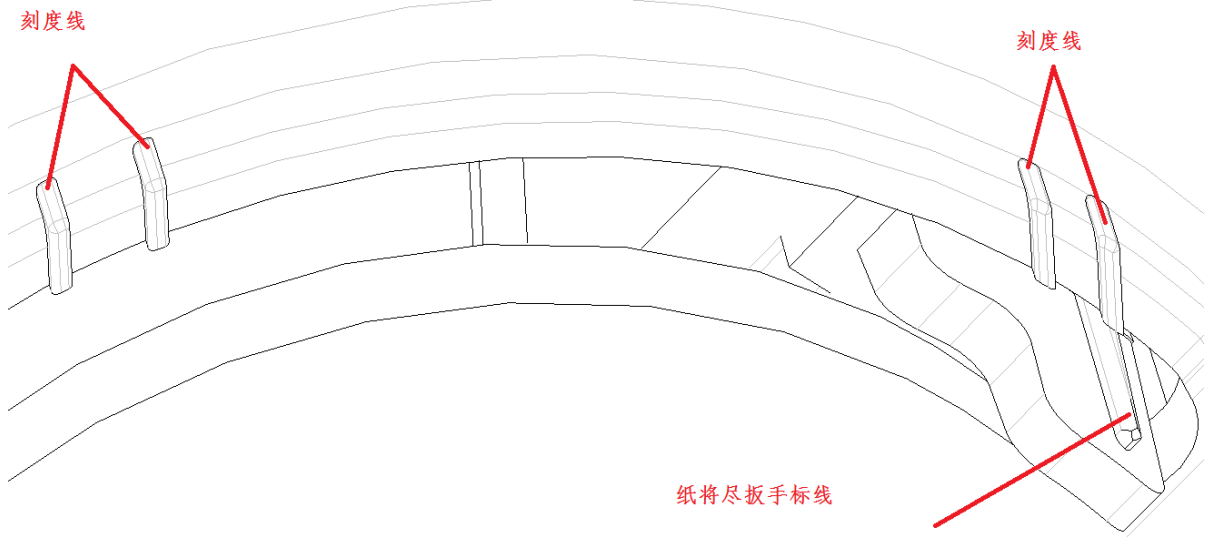

4.5-3

16.2mm

20.8mm

		1	2	1	16.2mm	2	20.8mm
3	4	3	20.8mm	4	16.2mm		

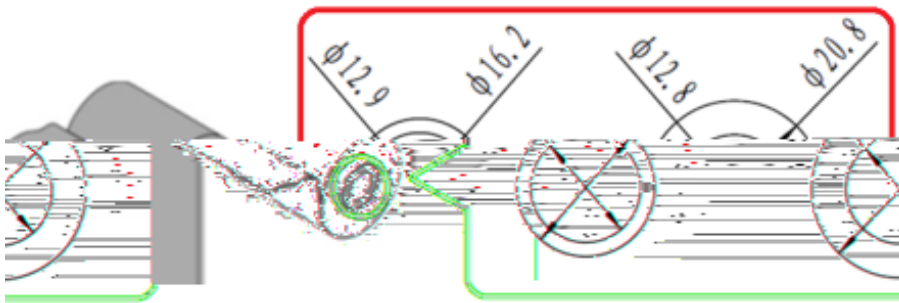

4.5-3

**4.6**

**4.6.1**

- 1)
- 2)

**4.6.2**

- 1)
- 2) POWER
- 3) FEED

“Press and Release FEED key

to print characters” “Press and Hold FEED key to config the printer”

Error

- 4) FEED

FEED

**4.7 Hexadecimal dumping**

Hexadecimal dumping

ASCII

Hexadecimal dumping

```

Hexadecimal Dump
To terminate hexadecimal dump,
press FEED button three times.

1B 21 00 1B 26 02 40 40 1B 69      . ! . . & . @ . i
1B 25 01 1B 63 34 00 1B 30 31      . % . . c 4 . . 0 1
41 42 43 44 45 46 47 48 49 4A      A B C D E F G H I J

*** completed ***
    
```

4.7-1

ASCII

3) Hexadecimal dumping

a.

b.

16

Hexadecimal dumping

ASCII

."

, DLE EOT, DLE ENQ, or DLE DC4

2



1

**5.1**

- 1)
- 2)
- 3)
- 4)

**5.2**

- 1)
- 2)
- 3)
- 4)

**5.3**

- 1
- 1)
- 2)
- 3)
- 2
- 1)
- 2)
- 3)

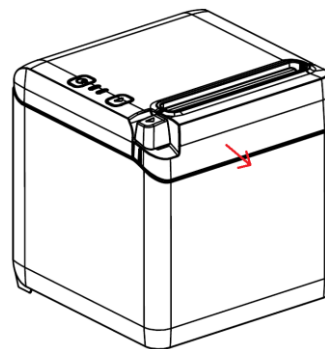

4.5

3



**6.1**

RS-232		D-SUB25	
Pin			
1	FG		House ground
2	TXD	Output	Data output
3	RXD	Input	Data input
5	NC		Not connected
6	DSR	Input	Data device is ready
7	SG		Signal ground
8 19	NC		Not connected
4, 20	DTR	Output	Require to send
21 25	NC		Not connected

**6.1-1**

115200bps 8

1

DTR/DSR

**6.2**

IEEE1284

36



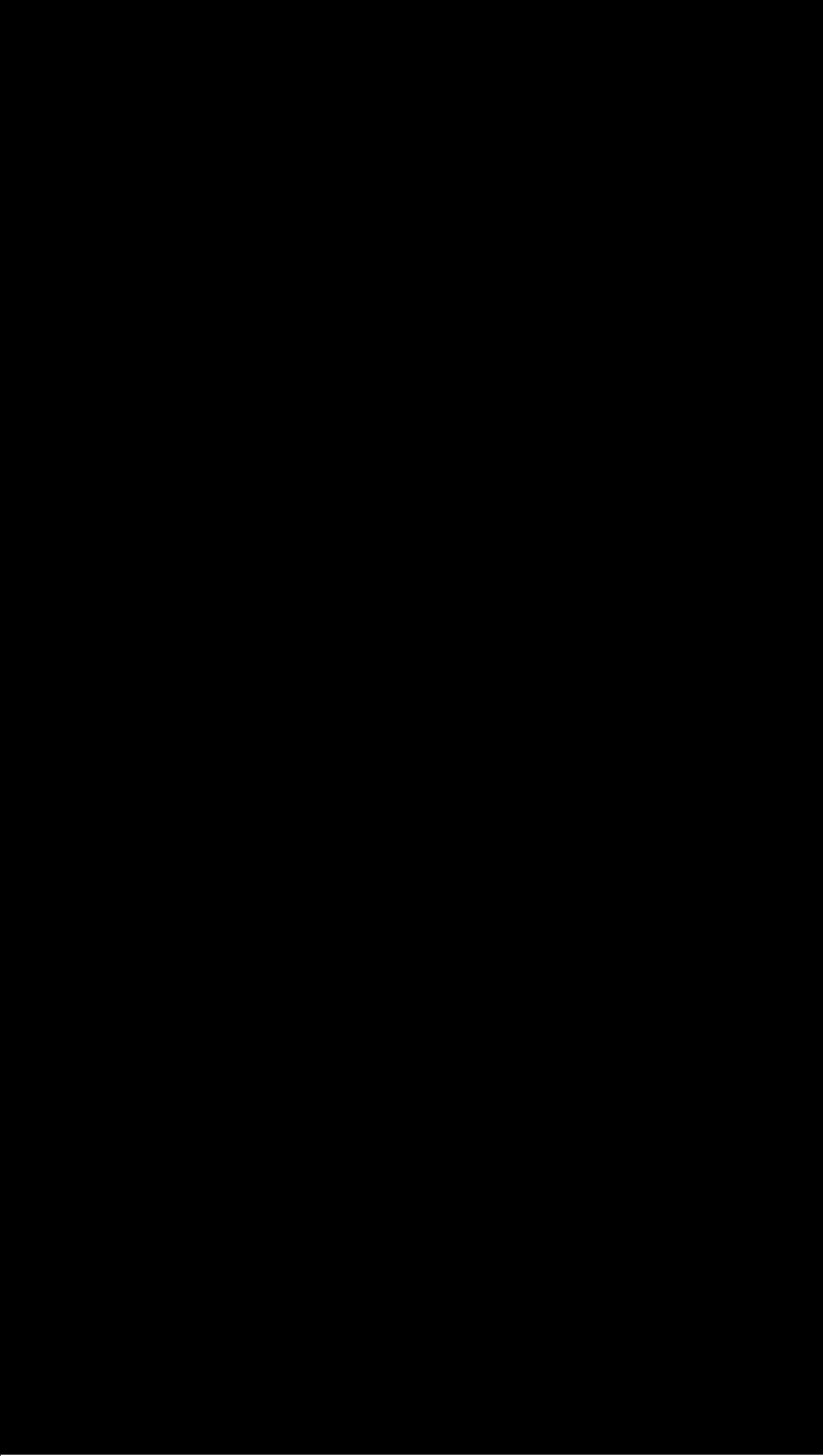

---

[Redacted content]

---



PIN 4	DTR
PIN 5	SG
PIN6	DSR
PIN 7	RTS
PIN 8	CTS
PIN 9	Not connected

2

6.4

**6.6**

1)

**100-240V AC**

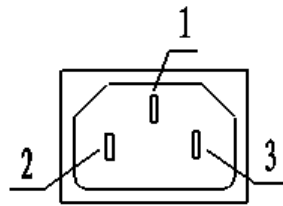

6.6-1

1	E
2	L
3	N

6.6-1

2)

**24V DC**

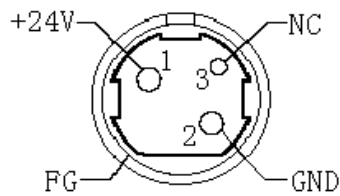

6.6-2 24V

**6.7**

1)

24 V

1 A

“L” = 0 0.5 V “H” = 3.3 V

2)

**RJ-11 6P**

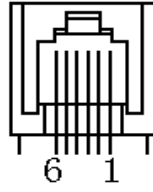

6.7-1

3)

1	FG	
2	DRAWER 1	1
3	DRSW	
4	VDR	
5	DRAWER 2	2
6	GND	

6.7-1



4



7.1



7.1-1

7.2



7.2-1

7.3



7.3-1

5



BTP-S80

2

6 M

DUMP

1 1D 28 41 02 00 00 01

2 FEED

ERROR

Hexadecimal Dump

To terminate hexadecimal dump, press FEED button three times

DUMP

DUMP

FEED

\*\*\*\*completed\*\*\*\*

DUMP

PARAMETER SETTING BY FEED							
BUTTON							
MAIN MENU							
Exit	->1						
Print Self Test	->2						
Configuration	->3	CONFIGURATION					
		Exit Without Save	->1				
		Exit With Save	->2				
		Communication	->3	Back To Last Menu	->1		
				USB Interface	->2	USB MODE:API MODE	
						Back To Last Menu	->1
				WinDriver Mode	->2		
				API Mode	->3		
		Serial Interface	->3	SERIAL INTERFACE			

			Back To Last	->1	
			Baud Rates	->2	BAUD RATES:115200bps
					Back To Last Menu ->1
					9600bps ->2
					19200bps ->3
					38400bps ->4
					57600bps ->5
					4800bps ->6
					2400bps ->7
					1200bps ->8
					115200bps ->9
			Parity	->3	PARITY:NONE
					Back To Last Menu ->1
					None ->2
					Odd ->3
					Even ->4
			Data Bits	->4	DATA BITS : 8 Bits
					Back To Last Menu ->1
					7 Bits ->2
					8 Bits ->3

				Back To Last Menu	->1
				1 Bit	->2
				2 Bits	->3

Handshaking

->6

HANDSHAKING:DTR/D



	Print Settings	->5	PRINT SETTINGS			
			Back To Last Menu	->1		
			Darkness Settings	->2	DARKNESS SETTING:	
					Back To Last	->1
					Low	->2
					Normal	->3
					High	->4
					Extra High	->5
			Paper Roll Width	->3	PAPER ROLL WIDTH:80.0mm	
					Back To Last Menu	->1
					57.5mm	->2
					80.0mm	->3
					82.5mm	->4
			Left Margin	->4	LEFT MARGIN:7mm	
					Back To Last	->1
					0mm	->2
					1mm	->3
					3mm	->4
				5mm	->5	
				7mm	->6	
				9mm	->7	

		Right Margin	->5	RIGHT MARGIN:9mm	
				Back To Last	->1
				Menu	
				0mm	->2
				1mm	->3
				3mm	->4
				5mm	->5
				7mm	->6
				9mm	->7
		CR Command	->6	CR COMMAND:	
				Disable	
				Back To Last	->1
				Menu	
				Enable	->2
				Disable	->3
		Code Page	->7	CODE PAGE SETTING	
				Back To Last	->1
				Menu	
				Print All	->2
				Codepages	
				Select A	->3
				Codepage	
		Save Paper Level	->8	SAVE PAPER LEVEL	
				Back To Last	->1
				Menu	
				Disable	->2
				25%	->3
				50%	->4

			75%	->5	
			100%	->6	
	Paper Sensor Settings	->6	PAPER NEAR END SETTINGS		
			Back To Last Menu	->1	
			Paper Low Alarm	->2	PAPER LOW ALARM: Enable
				Back To Last Menu	->1
				Enable	->2
				Disable	->3
			Stop Print When PAPER Low	->3	STOP PRINT WHEN
				Back To Last Menu	->1
				Enable	->2
				Disable	->3
			Paper Near End Sensor	->4	PAPER NEAR END SENSER: Enabled
				Back To Last Menu	->1
				Enable	->2
				Disable	->3
	Set Default Config	->7	SET DEFAULT CONFIGURATION		
			Back To Last Menu	->1	
			Set Printer To Default	->2	
	FONTA/FONTB Settings	->8	Current Font: FONTA		
			Back To Last Menu	->1	

		Select FONTA	->2		
		Select FONTB	->3		
		Select UDFONTA	->4		
		Select UDFONTB	->5		
	Beep settings	->9	Beep settings:Disabled		
		Back To Last Menu	->1		
		Enable External Herald	->2		
		Enable Internal buzzer	->3	BEEP MODE	
				Back To Last	->1
				Menu	
				Mode 1	->2
				Mode 2	->3
				Mode 3	->4
				Mode 4	->5
				Mode 5	->6
		All Beep disabled	->4		
	TestPage Settings	->10	TESTPAGEUPTODOWN PRINT: Disabled		
		Back To Last Menu	->1		
		Enable	->2		
		Disable	->3		
	Enter code,then hold Button Down				
Sensor Test	->4	Sensor Test Mode: ERROR LED state will			

